

10T  RW SERIES  
PLANETARY GEAR REDUCER

# **SZW PLANETARY REDUCER**

## **- RW SERIES PRODUCT**

### **Overview**

The hard surface wheel gear and nitride inside gear ring processing make it low noise. Consistent high standard manufacture confirms its load-carrying capacity and working reliability. The wheel gear was optimized by computer design, which has a high safety margin and mechanical efficiency.

### **Product Feature**

- Structure compact, space saving, two or three planetary gear transmission
- high load capacity shaft bearing system , may withstand the wire rope traction
- simple installation
- refuel convenient
- high efficiency , long life span

### **Applicable Scope**

Planetary reducer is suitable for all known windlass mechanism of cranes like car or crawler crane, railway crane, bridge crane, crown crane, ship deck and wharf crane. Because it can be installed in the inner of the roller very compactly, so it is easy to fix and space saving.

### **Working Condition**

Planetary reducer was design work at the temperature -20°C to +40°C. Some environmental factor will affect the product function like salt water, salty air, sand, super pressure and heavy vibration, severe impact and environment temperature, foreign sundries and so on. To confirm the safety of planetary reducer, these working conditions must be informed to the manufacturer.

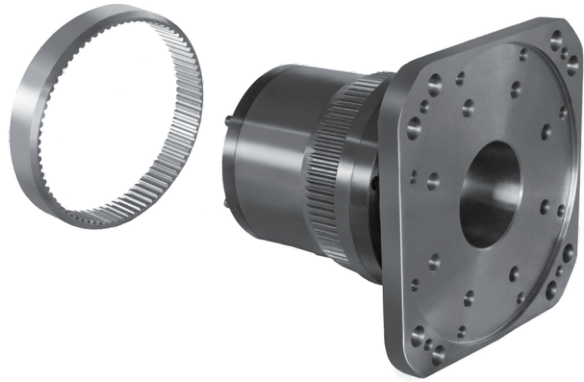

**PRODUCT MODELS**

Tonnages	Speed Ratios	Gear box Torques	gearmotor speeds	Drum Diameters	Product Models	Weights
3T	76	3000	1400	232	RW0376-3-3000-232	50.5kg
5T	56	5000		273	RW0356-5-5000-273	62kg
	78				RW0378-5-5000-273	
10T	81	10000		351	RW0381-10-10000-351	125kg
	110				RW03110-10-10000-351	
20T	81	26000		510	RW0381-20-26000-510	157.19kg
	131		RW03131-20-26000-510			
100T	140	42500		RW03140-100-42500	302kg	

## Install

Planetary reducer was added middle load industrial gear lubricants ISO VG 220 before they leave the factory.

Before installation, the connection of reducer must be cleaned up. The spline was welded in the roller to confirm the spline and roller connector coaxial. And then put the reducer into roller and connect with the rack stably. The M12 screw should be more than 10.9 grade

which are used for Lock reducer and rack. And screw the screws according to the torque of corresponding screw performance grade.

(10.9 grade screw tightening force torque is 100~110N·m)

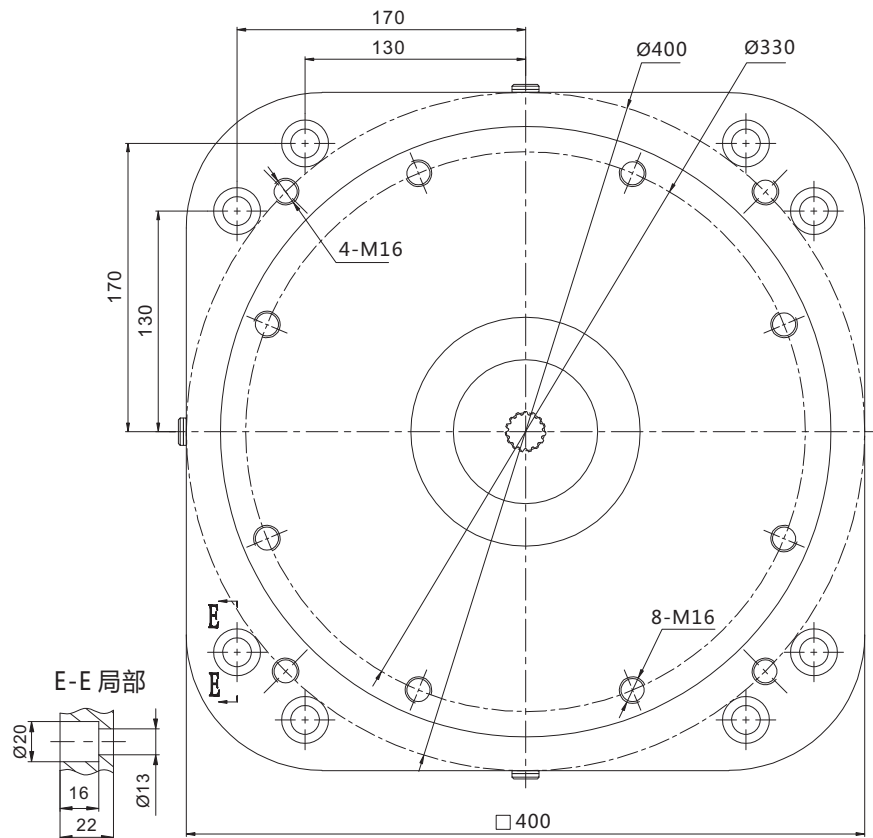

The rack used to fix planetary reducer must be fastness, support surface clean and perpendicular to the axis of the drive so that it can guarantee the rack and ruin vertical. Finally, the screw at the vent cap changed to vent cap. Vent cap was afford by the user. (the vent cap should be upward to avoid oil leakage)

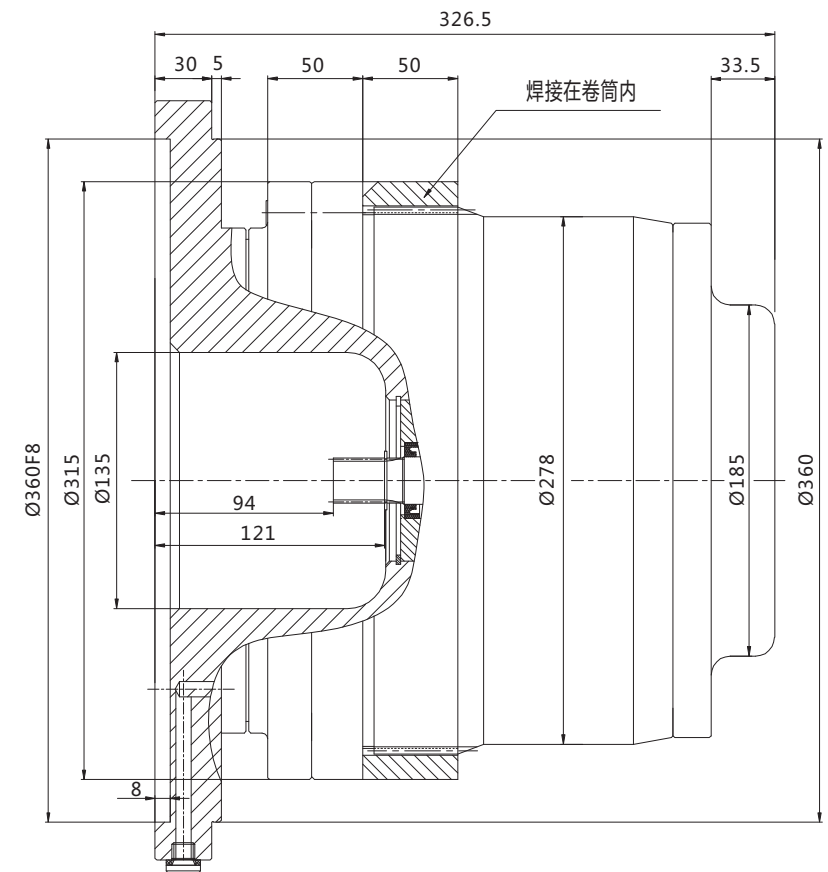

## Use and maintenance

1. Reducer can not be store and work in corrosive gas environment such as acid and alkali gas. The work temperature is  $-20^{\circ}\text{C}\sim 40^{\circ}\text{C}$ .
2. We suggest that in the use processing, the using torque value don' t exceed 70% of the max output torque value to lengthen the reduce life span. The max output torque value of this reducer is 3000N·m. The max output torque value must not be exceeded.
3. Reducer should change the gear lubricant after 2000-2500 hours use, or once a year. The gear lubricant change should be taken at reducer on high temperature, so it is easy to flow out. And please use the lubricating oil producers recommend liquid to clean the reducer inside. To improve the adding oil efficiency, please keep a certain number of oil pressure when add oil.  
(keep one oilhole adown and add to overflow from it; or add fix quantify about 0.29Kg )
4. Please don' t disassemble the inner of the reducer by yourself, and it should be disassemble by specialized persons from the manufacture to change parts. Otherwise we do not undertake any responsibility.

## Common failures and related measures

Abnormal	Possible Cause	Measures
Seal part oil leakage	Seal failure after long store	Clean related area and turn a few laps then check the oil leakage again
	Seal damage or abnormal	Inform the manufactures to manage
Overheating	Oil starvation	Add gear specified lubrication oil
Excessive vibration Excessive noise	Inner exception	Inform the manufactures to manage

